

# Agilent Technologies Wireless/GSM Solutions

Application Note 1312

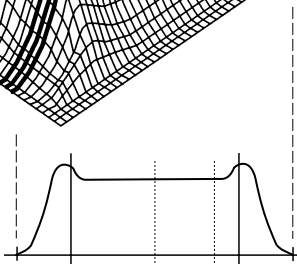

## Understanding GSM Transmitter and Receiver Measurements for Base Transceiver Stations and their Components

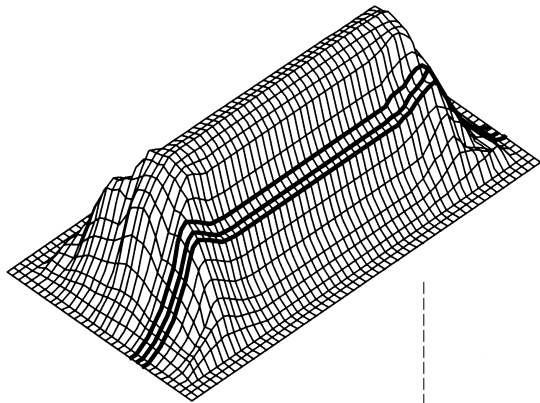
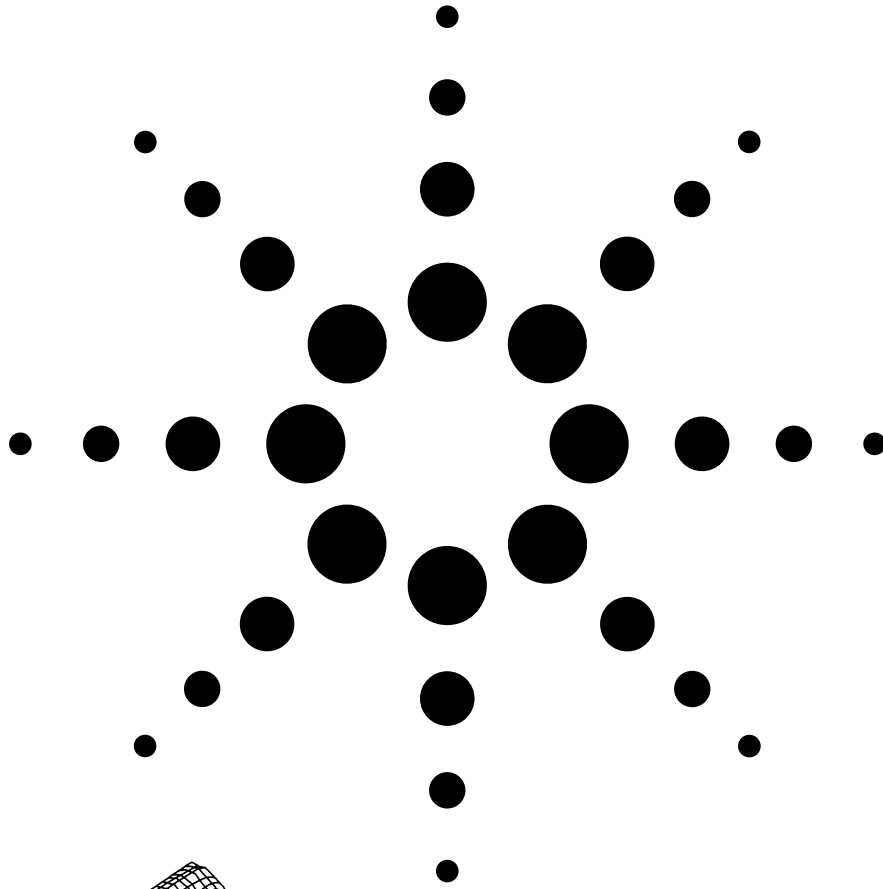
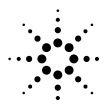

**Agilent Technologies**  
Innovating the HP Way

# Table of Contents

- Introduction ..... 4**
  - Why measure? ..... 4
  - Origin of measurements ..... 5
  - Choosing transmitter measurements ..... 6
    - Test phases ..... 6
    - Trade-offs and compromises ..... 6
- Base Station transmitter measurements in GSM ..... 7**
  - Phase error and mean frequency error ..... 7
    - Purpose of measurement—what it proves ..... 7
    - Theory in pictures ..... 7
    - Graphical view of limits and specifications ..... 8
    - Practical measurements ..... 9
    - When to use the measurement ..... 9
  - Mean transmitted RF carrier power ..... 10
    - Purpose of measurement—what it proves ..... 10
    - Theory in pictures ..... 10
    - Graphical view of limits and specifications ..... 11
    - Practical measurements ..... 12
    - When to use the measurement ..... 12
  - Transmitted RF carrier power versus time ..... 13
    - Purpose of measurement—what it proves ..... 13
    - Theory in pictures ..... 13
    - Graphical view of limits and specifications ..... 14
    - Practical measurements ..... 14
    - When to use the measurement ..... 14
  - Spectrum due to modulation and wideband noise ..... 15
    - Purpose of measurement—what it proves ..... 15
    - Theory in pictures ..... 15
    - Graphical view of limits and specifications ..... 16
    - Practical measurements ..... 16
    - When to use the measurement ..... 17
  - Spectrum due to switching ..... 18
    - Purpose of measurement—what it proves ..... 18
    - Theory in pictures ..... 18
    - Graphical view of limits and specifications ..... 19
    - Practical measurements ..... 19
    - When to use the measurement ..... 19
- Spurious ..... 20**
  - Purpose of measurements—what they prove ..... 20
  - Tx and Rx band spurious ..... 21
    - Theory in pictures ..... 21
    - Graphical view of limits/specifications ..... 21
    - Practical measurements ..... 22
    - When to use the measurement ..... 22
  - Cross-band spurious  
(for example, GSM900 into DCS1800) ..... 22
    - Graphical view of limits and specifications ..... 23
    - Practical measurements ..... 23
    - When to use the measurement ..... 23
  - Out-of-band spurious ..... 23
    - Graphical view of limits and specifications ..... 24
    - Practical measurements ..... 24
    - When to use the measurement ..... 24

<b>Choosing transmitter measurements for an application</b> .....	<b>.25</b>
<b>Receiver measurements in GSM basestations</b> .....	<b>.26</b>
Introduction .....	.26
Metrics .....	.26
BER .....	.26
RBER .....	.26
GSM speech coding .....	.27
FER .....	.27
Measurements .....	.28
Test setups .....	.28
Abis versus loopback .....	.28
Static versus multipath propagation .....	.28
Static reference sensitivity level .....	.29
Purpose of measurements—what it proves .....	.29
Theory in pictures .....	.29
Graphical view of limits and specifications .....	.29
Practical measurements .....	.30
When to use the measurement .....	.30
Reference interference level .....	.31
Purpose of measurements—what it proves .....	.31
Theory in pictures .....	.31
Graphical view of limits and specifications .....	.31
Practical measurements .....	.32
When to use the measurement .....	.32
<b>Additional ETSI 11.21 receiver tests</b> .....	<b>.33</b>
Statistic layer RX function .....	.33
Erroneous frame indication performance .....	.33
Blocking characteristics .....	.33
Intermodulation characteristics .....	.33
AM suppression .....	.33
<b>Summary</b> .....	<b>.34</b>
<b>References</b> .....	<b>.35</b>

## Introduction

This application note presents the fundamental RF parametric measurements necessary to characterize GSM900, DCS1800 and PCS1900 base transceiver stations and their components.

These measurements are widely used today, but new test equipment is making them easier to perform, faster and more precise. This note aims to enhance the reader's understanding of GSM measurements so they can be used and optimized appropriately. It is also intended as a useful reference for engineers in manufacturing, research and development and field service.

As far as possible, graphics are used to represent the theory behind each measurement and the test limits applied. For each measurement, pictorial examples of setup, method and specification limits are given. These have been derived from the ETSI and ANSI standards.

## Why measure?

The GSM standards define a radio communications system that works properly only if each component part operates within precise limits. Essentially a compromise is established between the link quality experienced by an individual user and the level of interference experienced by others. Mobiles and base stations must transmit enough power, with sufficient fidelity to maintain a call of acceptable quality, without transmitting excessive power into the frequency channels and timeslots allocated to others. Receivers must have adequate sensitivity and selectivity to acquire and demodulate a low-level signal.

Performance is critical in three areas: in-channel, out-of-channel, and out-of-band.

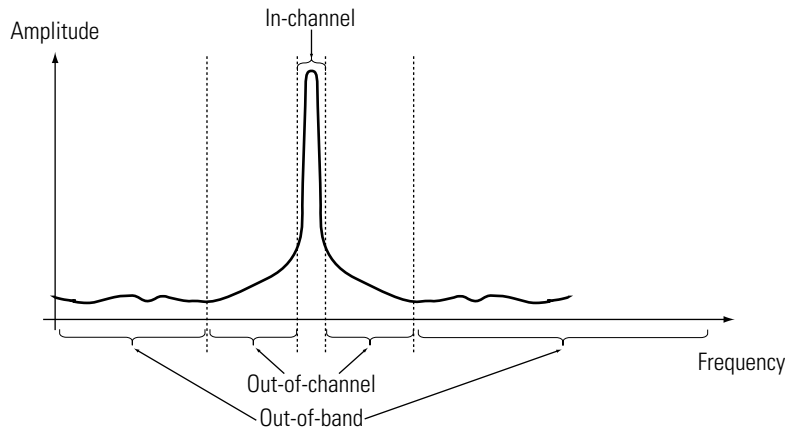

**Figure 1. In-channel, out-of-channel, out-of-band measurements**

In-channel measurements determine the link quality seen by the user in question:

- Phase error and mean frequency error*
- Mean transmitted RF carrier power*
- Transmitted RF carrier power versus time*

Out-of-channel measurements determine how much interference the user causes other GSM users:

- Spectrum due to modulation and wideband noise*
- Spectrum due to switching*
- Tx and Rx band spurious*

Out-of-band measurements determine how much interference the user causes other users of the radio spectrum (military, aviation, police):

- Other spurious (cross band and wideband)*

## Origins of measurements

GSM transmitter and receiver measurements originate from the following ETSI and ANSI standards:

- GSM 05.05/ETS 300-577. GSM and DCS1800 Radio transmission and reception.
- GSM 11.10/ETS 300-607. GSM and DCS1800 Mobile Station (MS) conformance specification. Part 1: Conformance specification.
- GSM 11.21/ETS 300-609. Base Station System (BSS) equipment specification. Part 1: Radio aspects.
- ANSI J-STD-007. PCS1900. Air Interface Specifications.

It is worth noting specifications were written for the purposes of full type approval and they are extensive. It is not practical to make the whole suite of measurements in most application areas. For example, in manufacturing where throughput and cost are key drivers, it is necessary to use a subset of the measurements defined in the specifications above. Optimization is key; the objective should be to test sufficiently to prove correct assembly, perform correct calibration and assure correct field operation, but with a minimum of expense. It is not necessary to type approve infrastructure component shipped.

This application note aims to help the reader to interpret the standards and apply tests appropriately.

The standards can be difficult to understand, and independent parties might interpret them differently. Agilent Technologies uses the standards as a basis from which to design measurement algorithms.

## Choosing measurements

As mentioned, ETSI and ANSI specifications are devised for type approval purposes. It is not practical to perform the complete set in every environment; GSM equipment manufacturers and network operators must balance test coverage with other factors such as cost and time. Nobody prescribes the specific measurement set to be used at any one point in the GSM lifecycle<sup>1</sup>—measurements must be chosen for each requirement. At each stage in the development, manufacturing and maintenance cycles, measurements and measuring equipment must be chosen according to need.

## Test phases

At a high level the GSM lifecycle for base transceiver stations (BTS) is summarized in the following diagrams:

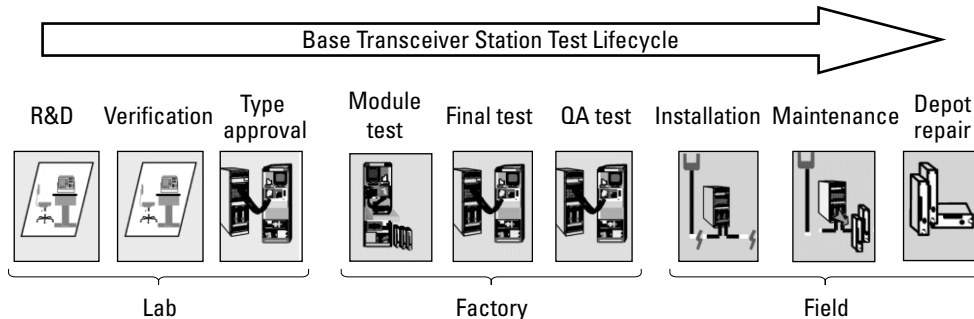

Lifecycle Phase	Purpose of Test
R&D	Create and optimize design Stress-test design/find corner cases
Verification	Prove compliance before submitting to type approval Find faults
Type approval	Prove absolute compliance
Module test	Calibration (manual and electronic) Prove correct assembly and performance
Final test	Prove correct assembly and performance Configure and prove configuration Confidence
QA test	Quality control Prove compliance/confidence End-customer demonstration
Installation	Prove correct field operation Configure and prove configuration
Maintenance	Monitor performance degradation and repair/swap out as required
Depot repair	Repair/recalibrate modules for field

Figure 2. BTS lifecycle

## Trade-offs and compromises

It is not necessary or practical to make the whole suite of measurements, with the same integrity (accuracy, dynamic range and number of averages) at each point in the lifecycle. Generally the following factors are subject to trade-offs:

- Test cost*
- Test coverage*
- Test throughput*
- Test system flexibility*

The test cost of each unit can be reduced by performing measurements only on the devices that have a real possibility of failing or performing only the measurements required for device characterization.

1. Exceptions: first, the ETSI and ANSI specifications do define the test suite for type approval. Also, in certain countries regulatory bodies do recommend a test list for unit manufacturing final test and also for installation and maintenance test.

# Base station transmitter measurements in GSM

## Phase error and mean frequency error

Note: For each measurement, process and limits vary between device type.

### Purpose of measurement—what it proves

Phase error is the fundamental parameter used in GSM to characterize modulation accuracy. These measurements reveal much about a transmitter's modulator performance. Poor phase error indicates a problem with the I/Q baseband generator, filters or modulator in the transmitter circuitry. The output amplifier in the transmitter can also create distortion that causes unacceptably high phase error. In a real system, poor phase error will reduce the ability of a receiver to correctly demodulate, especially in marginal signal conditions. This ultimately affects range.

Frequency error measurements indicate poor synthesizer/phase lock loop performance. This is especially important in a BTS with frequency hopping active. Poor frequency error measurements can show, for example, that a synthesizer is failing to settle quickly enough as it shifts frequency between transmissions. In a real system poor frequency error can cause many problems, for example, the target receiver might be unable to gain lock and the transmitter might cause interference with other users. If the latter is the case, other measurements can determine this with certainty.

### Theory in pictures

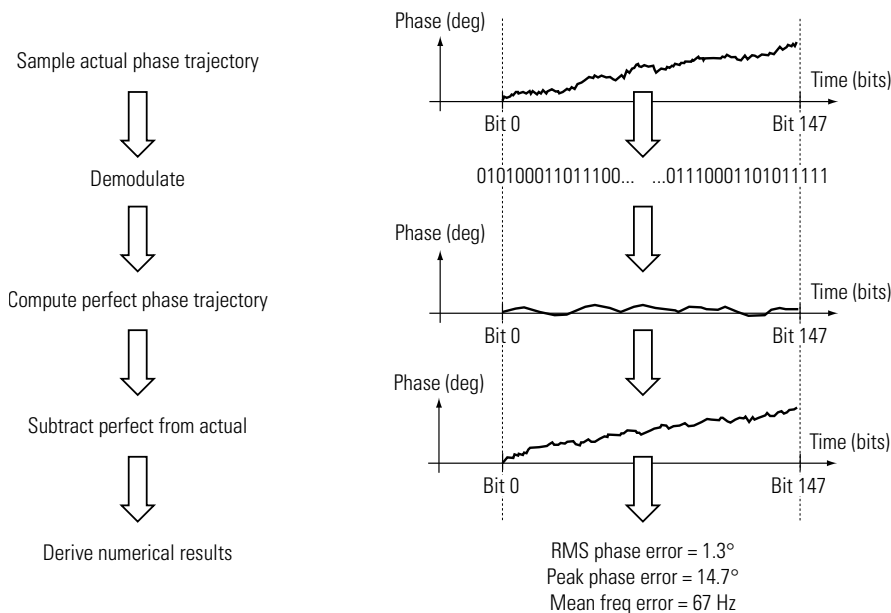
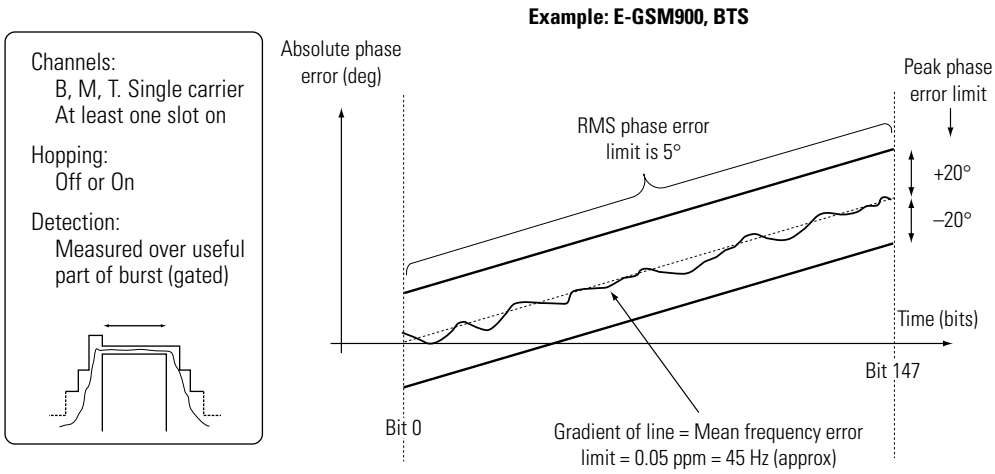

Figure 3. Theory of phase error and mean frequency error

Phase and frequency error measurements are complex, however modern test equipment can perform all of the necessary signal processing and mathematics automatically. Figure 3 shows how the measurement works. The test receiver or analyzer samples the transmitter output in order to capture the actual phase trajectory. This is then demodulated and mathematically the ideal phase trajectory is derived. Subtracting one from the other results in an error signal. The mean gradient of this signal (phase/time) gives frequency error. The variation of this signal is defined as phase error and is expressed in terms of root mean squared (RMS) and peak.

### Graphical view of limits and specifications

The ETSI and ANSI specifications define test limits for both base transceiver stations and mobiles. Phase and frequency error measurements should be performed over multiple bursts, and on multiple channels. Actual transmitter performance will vary with frequency.



**Figure 4. Phase error and mean frequency error, BTS, limits**

It is worth noting that for frequency error the pass/fail limit is expressed in terms of ppm (parts per million) and applies across GSM900, DCS1800 and PCS1800. The phase error limits are also common across the three systems.



## Practical measurements

As mentioned, modern test equipment performs the necessary signal processing automatically, making these measurements straightforward and fast. It is also useful to view phase error versus time—especially in R&D and when fault finding. For example, a phase and frequency error test might fail the prescribed limits at only one point in the burst, for example, at the beginning. This could indicate a problem with the transmitter power ramp or some undesirable interaction between the modulator and power amplifier.

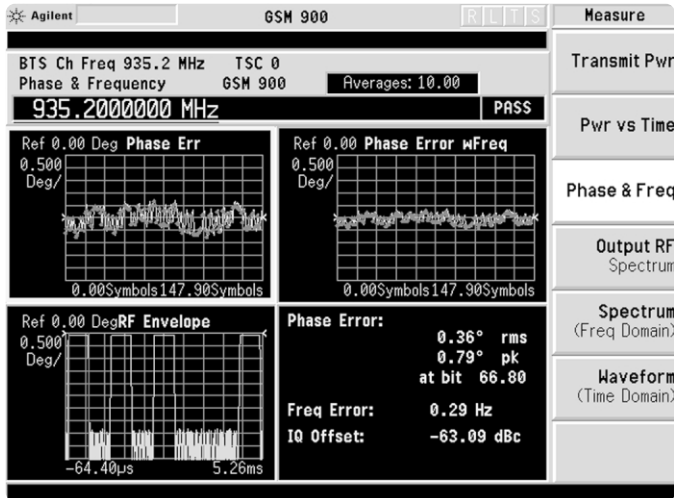

Figure 5. Quad display of the Agilent E4406A VSA-series transmitter tester with and without frequency error

Constellation diagrams can also be used to observe some aspects of modulation accuracy and can reveal certain fault mechanisms such as I/Q amplitude imbalance or quadrature imbalance.

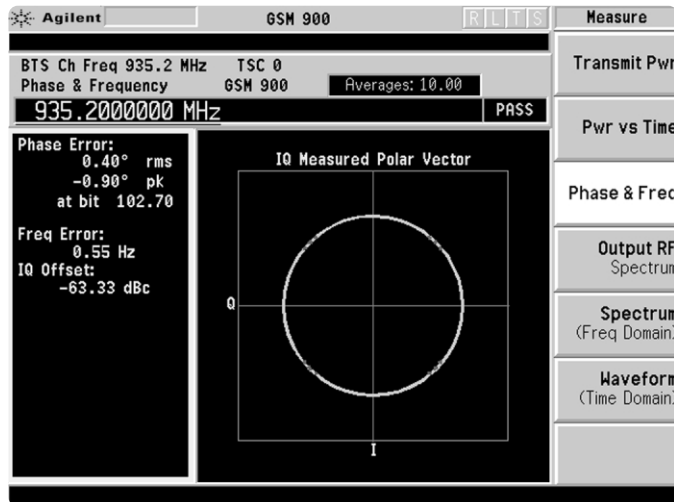

Figure 6. Constellation diagram on the Agilent E4406A VSA-series transmitter tester

## When to use the measurement

Phase and frequency error measurements can capture a large spread of fault types and prove that any I/Q calibration process has been successfully performed. These measurements are typically used at every stage in the BTS lifecycle. Modern test equipment can make these measurements very rapidly and with good accuracy (typically the test equipment should be 10x more accurate than the specification limit so measurement results can be attributed to the device under test and not the test system).

## Mean transmitted RF carrier power

### Purpose of measurement—what it proves

Output power is a fundamental transmitter characteristic and is linked directly to range. GSM systems use dynamic power control to ensure that each link is maintained sufficiently with a minimum of power. This gives two fundamental benefits: overall system interference is kept to a minimum and, in the case of mobile stations, battery life is maximized.

Therefore, output power is controlled within tight limits. If a transmitter produces too little power, link performance is compromised; too much, and interference to others might be too high and battery life too short.

Common practical transmitter implementations require output power calibration in manufacturing to meet the GSM specifications (this allows low-cost components to be used). This calibration process involves the construction of a table of calibration factors for power steps and frequency. Power calibration corrects for the effects of component variation.

Out-of-specification power measurements indicate a fault, usually in the power amplifier circuitry or the calibration tables. They can also provide early indication of a fault with the power supply.

### Theory in pictures

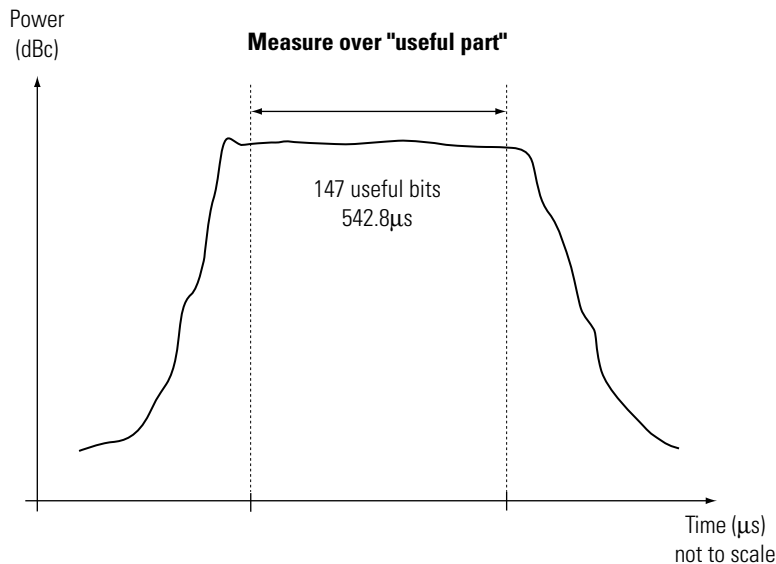

Figure 7. Theory of mean transmitted RF carrier power

Conceptually, the mean power measurement in GSM is straightforward. It is defined as the mean power during the useful part of the GSM burst. The ETSI and ANSI specifications define that in type approval (at least) test equipment must be capable of deriving the correct timing reference by demodulating the incoming signal, and gating over the useful part only.

Most base transceiver stations implement dynamic power control. This makes it necessary to make multiple power measurements at several power levels and several frequencies in order to test for proper operation.

## Graphical view of limits/specifications

The ETSI and ANSI specifications define power limits both in terms of absolute accuracy and relative accuracy (between power levels or 'steps').

The examples given in Figure 8 are for transmitters of a specific type and class. Absolute limits depend on the type and class of the device under test.

### Example: E-GSM900, Class 5 BTS with dynamic power control, normal conditions

Note: typical max power for a GSM BTS TRX = 43 dBm

**Channels:**  
B, M, T. Single carrier  
At least three slots on

**Hopping:**  
On

**Detection:**  
Measured over useful part of burst (gated)

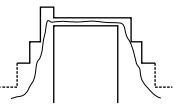

**Log average**

**Notes:** Absolutes depend on power class of BTS. The six or more 'power settings' for radio planning are neglected here.

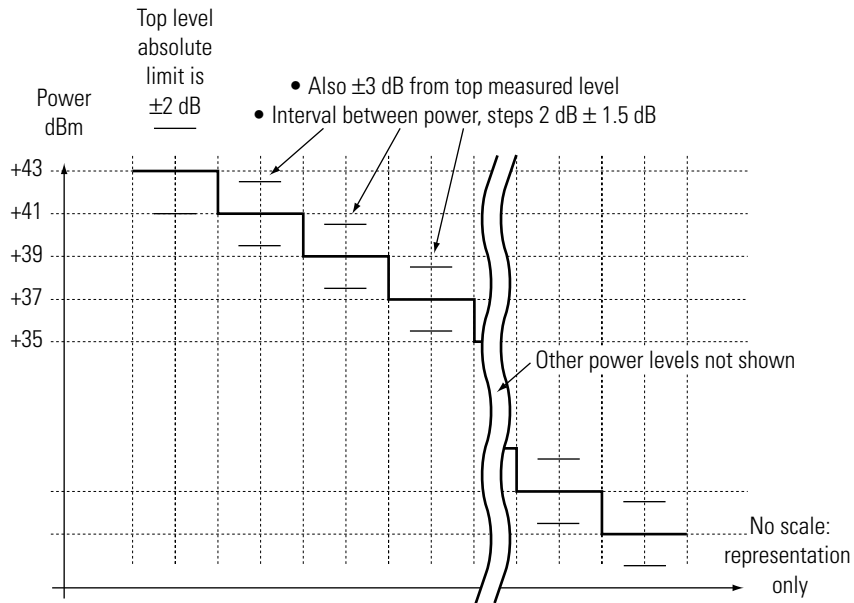

Figure 8. Mean transmitted RF carrier power, BTS, limits

## **Practical measurements**

In practice, many types of test equipment can be used to make power measurements in GSM systems. Accuracy, linearity and repeatability are key here and the performance required from test equipment depends on the application.

It is possible to make power measurements in GSM systems by triggering off the rising edge of the signal instead of the bit 13/bit 14 transition, although this method will result in increased levels of uncertainty.

It is also possible to use either a peak or thermal power sensor with a conventional meter. Both sensor types should be used with care. Peak power sensors will capture the overshoot at the top of the burst's ramp up and give incorrect readings, and thermal sensors will give results that are largely affected by the burst shape differences from one transmitter to the next.

Some modern test equipment, suitable for GSM R&D, manufacturing and installation and maintenance can make this measurement as defined in the ETSI and ANSI specifications by demodulating and gating.

Note: power measurements are extremely vulnerable to mismatch. If the transmitter output to test equipment input is not matched properly, and some energy is reflected back into the transmitter, the test equipment will give a low power reading.

## **When to use the measurement**

Power measurements are normally performed in every phase of the BTS lifecycle. Accuracy, linearity and repeatability requirements typically are more stringent in R&D than in installation and maintenance.

In manufacturing where power calibration is required, measurement speed is a significant factor. To fully calibrate and characterize, for example, a GSM BTS transceiver in manufacturing might require hundreds of measurements.

## Transmitted RF carrier power versus time

### Purpose of measurement—what it proves

This measurement assesses the envelope of carrier power in the time domain against a prescribed mask. In GSM systems transmitters must ramp power up and down within the time division multiple access (TDMA) structure to prevent adjacent timeslot interference. If transmitters turn on too slowly, data at the beginning of the burst might be lost, degrading link quality, and if they turn off too slowly the user of the next timeslot in the TDMA frame will experience interference. This measurement also checks that the transmitters' turn off is complete.

If a transmitter fails the “transmitted RF carrier power versus time” measurement, this usually indicates a problem with the unit’s output amplifier or leveling loop.

This measurement does not test to see if the transmitter ramps power too quickly, which has the effect of spreading energy across the spectrum and causing interference. The “spectrum due to switching” measurement can be used to test for this effect.

### Theory in pictures

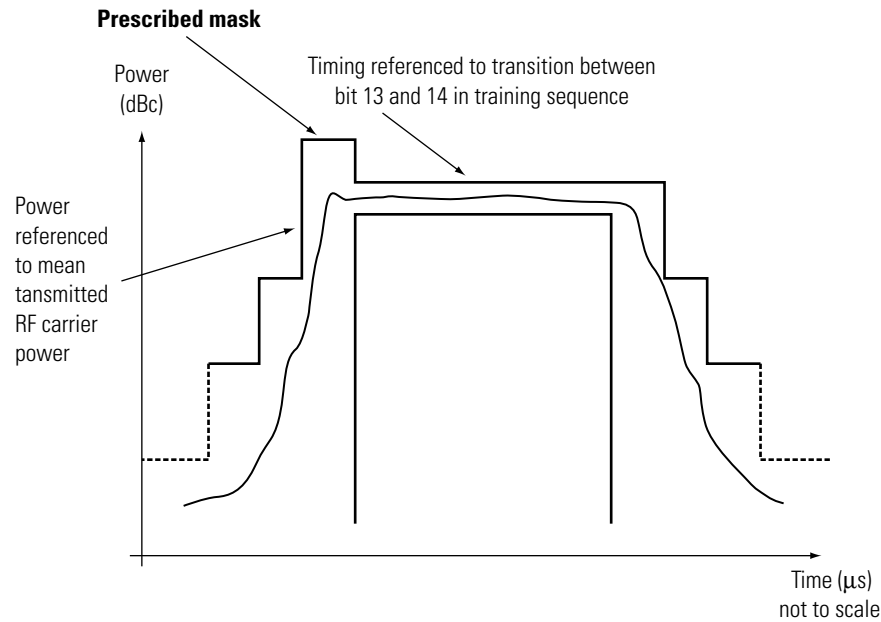

Figure 9. Theory of transmitted RF carrier power versus time

The measurement of transmitted RF carrier power versus time is made using an analyzer in zero-span mode. The pass/fail mask is placed over the measured trace and referenced in two ways. Horizontally (time axis), the measurement is referenced from the transition between bits 13 and 14 of the training sequence. Therefore, as with mean transmitted RF carrier power, it is necessary for the test equipment to demodulate to make this measurement correctly. Vertically (power axis), the measurement is referenced against the measurement of mean transmitted RF carrier power.

## Graphical view of limits and specifications

### Example: E-GSM900, BTS

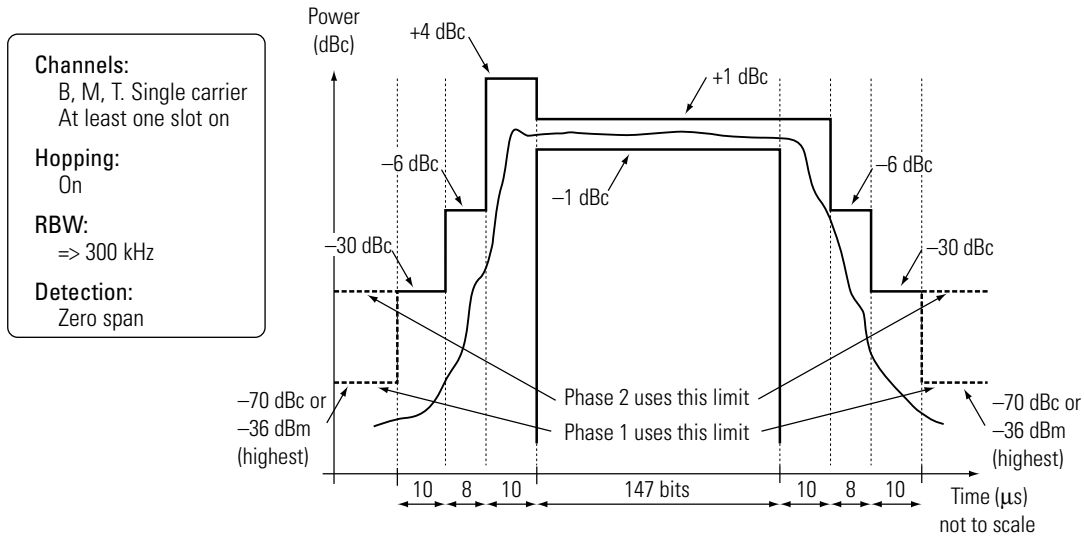

Figure 10. Transmitted RF carrier power versus time, BTS, limits

As shown in Figure 10, the limit lines for BTS are dependent on a number of factors, the most fundamental being the output power level of the transmitter. The absolute limit values are also dependent on system—Figure 13 show limits for E-GSM900. DCS1800 and PCS1900 use slightly different pass/fail criteria.

## Practical measurements

In practice, most power-versus-time failures occur either towards the top of the rising edge or falling edge. However, it is also important at most points in the BTS lifecycle to ensure that the turn on/turn off ratio is sufficient. For this measurement the analyzer used must have adequate dynamic range.

For the purposes of adjustment, it is extremely useful to view power versus time in real time against the prescribed mask because many GSM transmitters have multistage turn on/turn off circuits which require calibration.

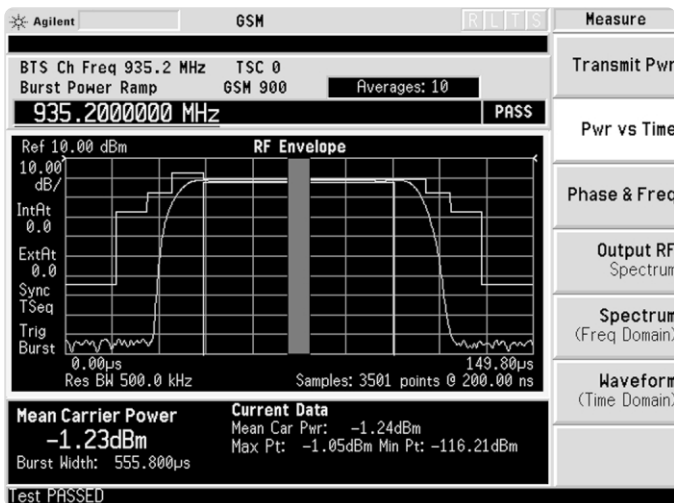

Figure 11. Agilent E4406A VSA-series transmitter tester screen shot, PVT, high dynamic range-rising and falling edge

## When to use the measurement

From R&D through to installation, maintenance, and service, power-versus-time measurements are used universally in GSM applications to check the functioning of transmitters.

## Spectrum due to modulation and wideband noise

### Purpose of measurement—what it proves

This measurement and the next “spectrum due to switching,” are often grouped together and called “output RF spectrum” (ORFS).

The modulation process in a transmitter causes the continuous wave (CW) carrier to spread spectrally. The “spectrum due to modulation and wideband noise” measurement is used to ensure that modulation process does not cause excessive spectral spread. If it did, other users who are operating on different frequencies would experience interference. The measurement of spectrum due to modulation and wideband noise can be thought of as an adjacent channel power (ACP) measurement although several adjacent channels are tested.

This measurement, along with the phase error measurement, can reveal numerous faults in the transmit chain, for example, faults in the I/Q baseband generator, filters and modulator.

As defined, the measurement also checks for wideband noise from the transmitter. The specification requires the entire transmit band to be tested. Again, if the transmitter produces excessive wideband noise, other users will experience interference.

### Theory in pictures

Measure carrier power in pre-defined bandwidth (gated from 50–90% of burst)



Tune to offset frequency



Measure power at offset in pre-defined bandwidth (gated from 50–90% of burst)



Subtract offset power from carrier power  
Report relative (dBc) result



Repeat through offset list

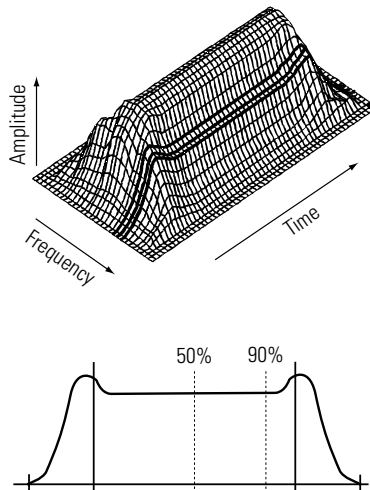

Figure 12. Theory of spectrum due to modulation and wideband noise

The measurement is defined and designed as follows. The analyzer is tuned to a spot frequency and then time-gated across part of the modulated burst. Power is then measured using this mode and then the analyzer is re-tuned to the next frequency, or offset of interest. This process continues until all offsets are measured and checked against permissible limits. What results is the “spectrum” of the signal, however, spectral components that result from the effect of bursting do not appear because the ramps are gated out.

Note: the result of the measurement is a set of frequency/power points, this is not a swept measurement (with the exception of offsets beyond 1800 kHz in the BTS case).

The test limits are mostly expressed in relative terms (dBc) so the first step of the measurement is to take a reading at the center frequency to which the transmitter is tuned. Because this measurement is gated and a different bandwidth is used, this reading will not be the same as the mean transmitted RF carrier power measurement. In practice the latter is approximately 8 dB higher but this does depend on the spectral shape of the signal.

## Graphical view of limits and specifications

As with other measurements, the actual limits depend on many factors, namely, class, type, system and power level. Figure 13 gives example limits for EGSM900 MS and Normal BTS at high power.

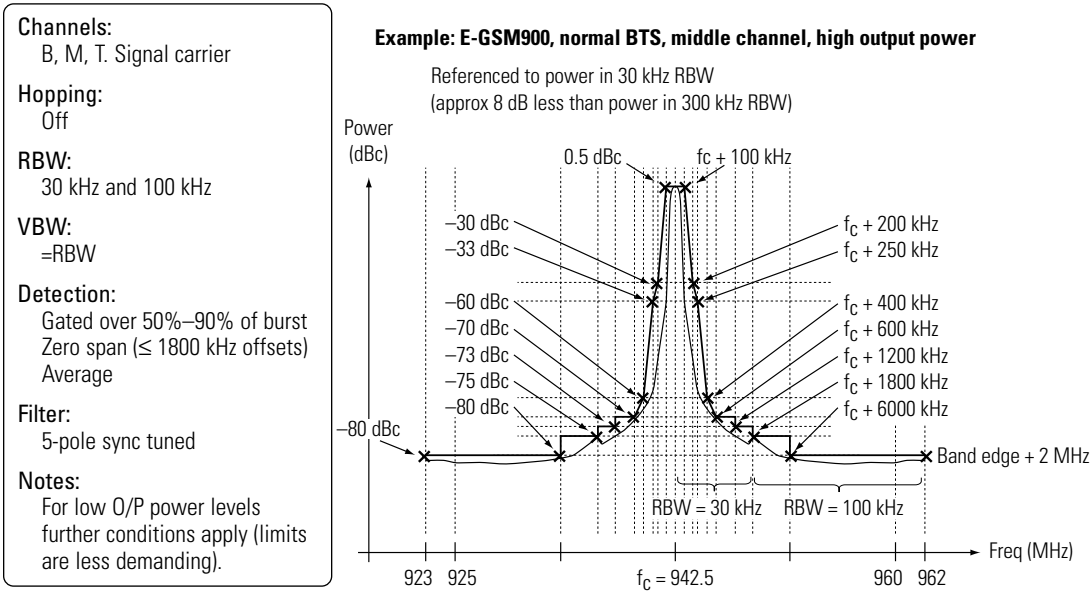

Figure 13. Spectrum due to modulation and wideband noise, normal BTS, limits

## Practical measurements

Spectrum due to modulation and wideband noise measurements are both difficult and time consuming if made precisely as the ETSI and ANSI type approval specifications require. It is normal to perform some subset of the defined measurement set in most applications for time and/or cost reasons.

At wide offsets such as 600 kHz and above, these measurements require high dynamic range—this has historically been expensive. They also require a large amount of processing power if they are to be done rapidly. In some applications the complete suite of spectrum due to modulation and wideband noise measurements are only performed on a sample basis.

Historically, standard spectrum analyzers have been used, and when provided with an appropriate gate signal this method works well. However, this time-consuming technique requires a series of separate measurements and frequent re-tuning. The VSA-series transmitter tester provides two techniques for overcoming this problem.

First, with a wide bandwidth sampler, it is possible to perform many of the close-in measurements up to 600 kHz, using DSP techniques—essentially FFTs. This means that several measurements can be performed on the same sample set, which results in a significant speed improvement.

A further speed improvement can be achieved by measuring over a greater portion of the burst. The standards define that these measurements should be performed over the 50%–90% portion of the burst. However, for practical speed improvement, it is quite reasonable to measure over 10%–90% portion of the burst.



Last, at wide offsets it is possible to pre-attenuate, or notch out the central part of the GSM signal (in the frequency domain). This gives a significant dynamic range improvement.

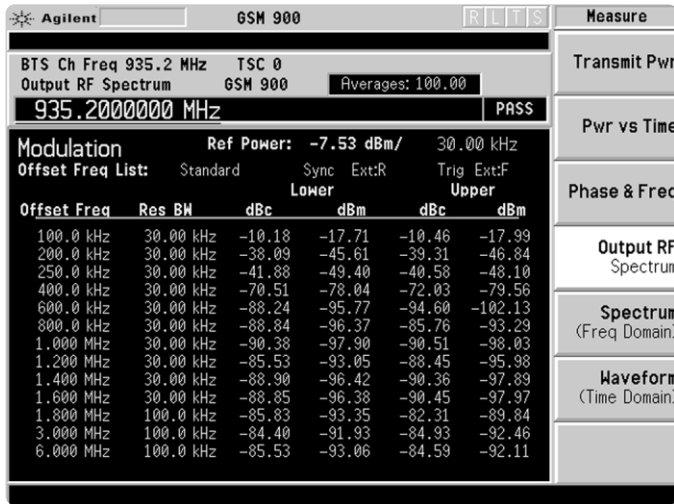

Figure 14. Theory of output RF spectrum due to modulation on the Agilent E4406A VSA-series transmitter tester

### When to use the measurement

This measurement is important because it defines how much a transmitter will interfere with other users. For this reason this measurement is commonly used in BTS R&D and manufacturing. Usually, due to time constraints, only a subset of the prescribed list of offsets is used. For example, in manufacturing, choosing an appropriate frequency offset list depends greatly on the transmitter design.

## Spectrum due to switching

### Purpose of measurement—what it proves

GSM transmitters ramp RF power rapidly. The “transmitted RF carrier power versus time” measurement is used to ensure that this process happens at the correct times and happens fast enough. However, if RF power is ramped too quickly, undesirable spectral components exist in the transmission. This measurement is used to ensure that these components are below the acceptable level.

If a transmitter ramps power too quickly, users operating on different frequencies, especially those close to the channel of interest, will experience significant interference.

Failures with this measurement often point to faults in a transmitter’s output power amplifier or leveling loop.

### Theory in pictures

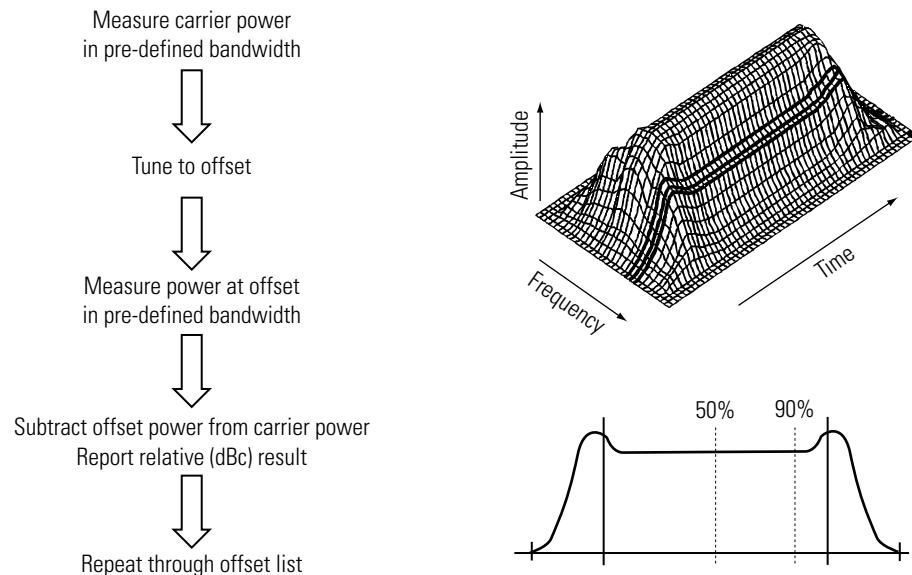

Figure 15. Theory of spectrum due to switching

Measurements of spectrum due to switching are performed in a similar fashion to the measurement of spectrum due to modulation and wideband noise. The analyzer is tuned to and measures at multiple offset frequencies in zero-span mode. In this case no time gating is used, so power from both the ramping and modulation processes affect the measurement. The effect of ramping dominates the spectrum due to switching measurements.

Again, the specifications are relative so the first step in the process is to establish a reference. This reference is once again not the same as “mean transmitted RF carrier power” in the way that it is measured (resolution bandwidth = 300 kHz).

## Graphical view of limits and specifications

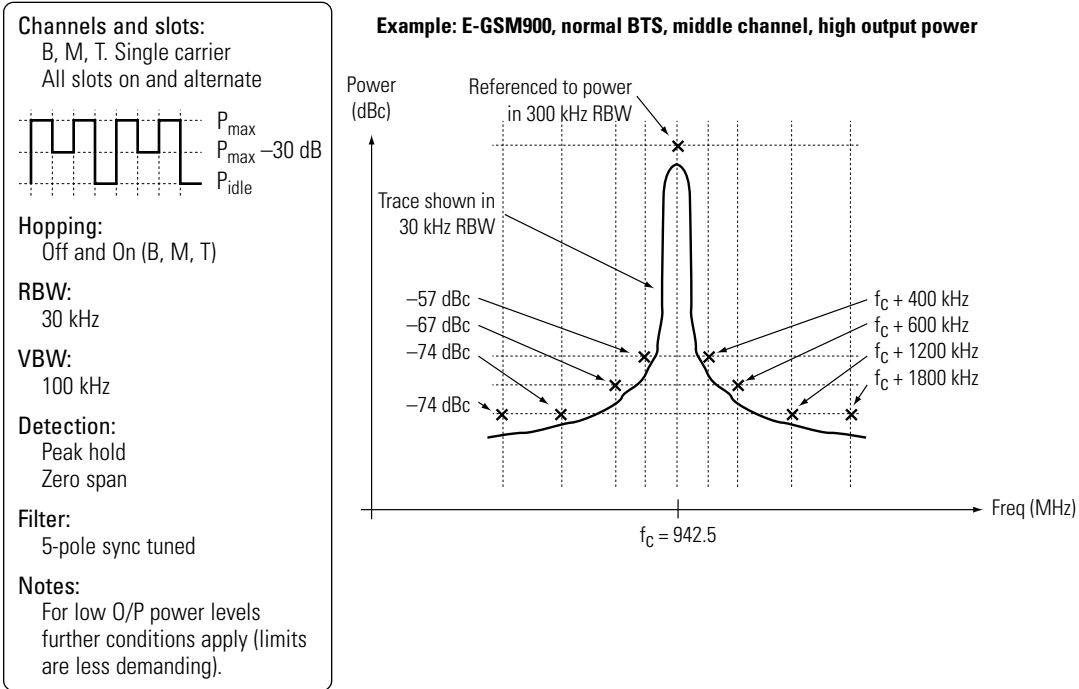

Figure 16. Spectrum due to switching, BTS, limits

As with other measurements the actual limits depend on many factors, namely, class, type, system and power level. Figure 16 gives example limits for E-GSM900 normal BTS at high power.

### Practical measurements

Spectrum due to switching measurements are less difficult and less demanding than spectrum due to modulation and wideband noise measurements. In practice, equipment that can perform the latter can easily manage the former.

### When to use the measurement

Spectrum due to switching measurements are usually performed alongside spectrum due to modulation and wideband noise measurements.

## Spurious

### Purpose of measurements—what they prove

Spurious measurements are necessary in all radio communications systems, and in GSM they are extensive. For correct operation GSM transmitters must not put energy into the wrong parts of the spectrum. If they do, other users of the GSM system may experience interference and worse still, other users of the radio spectrum (for example, police, television, commercial radio, military and navigation) will experience degraded, or even jammed links.

Almost any fault in the transmitter circuits can manifest itself as spurious of one kind or another.

The spurious measurements discussed in this section are those defined as “conducted.” These specifications apply when the test instrumentation is connected directly to the device under test antennae connector. The ETSI and ANSI standards also defined a large number of measurements for “radiated” spurious. These are not covered in this note.

For the purposes of clarity, in terms of representing the specifications, this section is broken down as follows:

Tx and Rx band spurious	Spurious that affect the system of interest.
Cross-band spurious	Spurious that affect other GSM systems operating at different frequencies (GSM900 into DCS1800).
Out-of-band spurious	Wideband spurious that affects other users of the radio spectrum.

All of the spurious measurements are defined in ETSI and ANSI specifications as standard spectrum analyzer measurements, that is, a band is swept (with certain filter/speed settings) and a pass/fail limit applied.

## Tx and Rx band spurious

### Theory in pictures

Tx band spurious is a measurement set that checks that the transmitter does not put undesirable energy into the wrong parts of the Tx band (925–960 MHz for E-GSM). This measurement reveals little more than the switching due to modulation and wideband noise measurement, however, it is a swept measurement with no time gating.

The Rx band spurious measurement deserves special attention. This is a measure of how much energy the transmitter puts into the Rx band (880–915 MHz for E-GSM) and the specification is extremely stringent. The reasons for this are clear; potentially spurious from the transmitter can “jam” or “deafen” the receiver, making the system useless. The Rx band spurious measurement deserves a special explanation. See Figure 17.

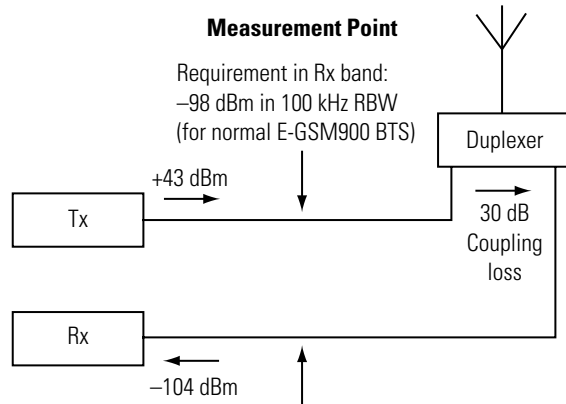

The requirement corresponds to -128 dBm in 100 kHz RBW here. The signal leaking from the transmitter to the receiver is approx 24 dB below the 'worst case' receiver signal of -104 dBm. If it were much higher the transmitter would "deafen" the receiver.

Figure 17. Theory of Rx band spurious

### Graphical view of limits and specifications

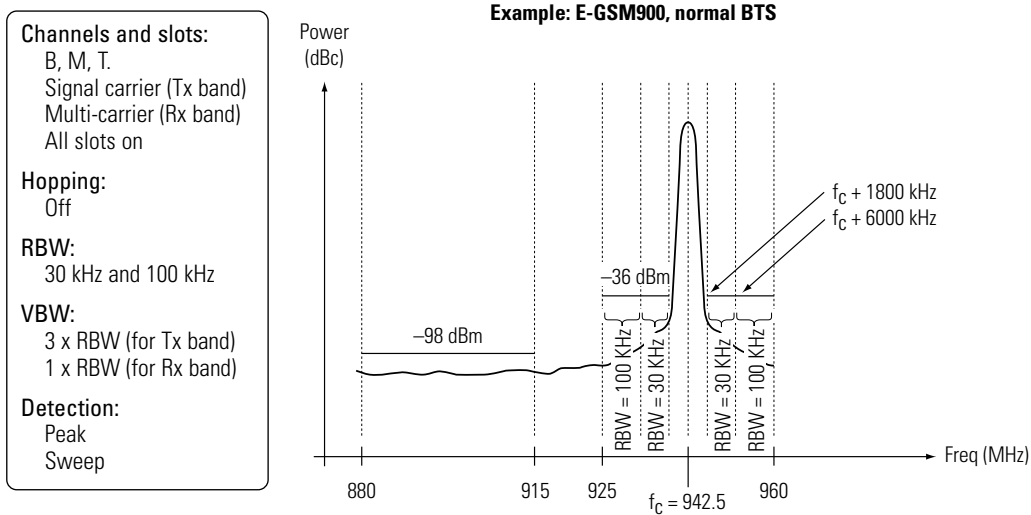

Figure 18. Tx and Rx band spurious, BTS, limits

## **Practical measurements**

To date, no analyzer has sufficient dynamic range to measure Rx band spurious to the ETSI and ANSI specifications directly. Usually a Rx bandpass filter is used in front of the analyzer input to attenuate the Tx band signal.

As with all spurious measurements it is possible to speed up the process for BTS manufacturing by simply checking selected or “at risk” parts of the band. In other words, through design analysis and experimentation it is possible to determine at which frequencies the transmitter is most likely to fail and then test only at these frequencies to minimize test time.

## **When to use the measurement**

The application of Tx band spurious measurements should be considered alongside the application of spectrum due to modulation and wideband noise measurements because there is some redundancy here. It is reasonable, in manufacturing for example, to perform the spectrum due to modulation and wideband noise measurement only up to and including the 1800 kHz offset ( $\pm$ ) and then apply the Tx band spurious measurement, if needed, to check the rest of the the Tx band.

As with spectrum due to modulation and wideband noise, Tx and Rx band spurious measurements need not be comprehensively performed outside of R&D, verification and type approval. A limited subset of these measurements can be derived and used in manufacturing and the field service for cost and time reasons.

## Cross-band spurious (for example, GSM900 into DCS1800)

In some countries GSM900 and DCS1800 systems exist together and in some cases base stations for both systems are co-sited. For this reason the ETSI standards require specific cross-band performance. For example GSM900 transmitters must put a minimum of energy into DCS1800 Tx and Rx bands and vice-versa.

### Graphical view of limits and specifications

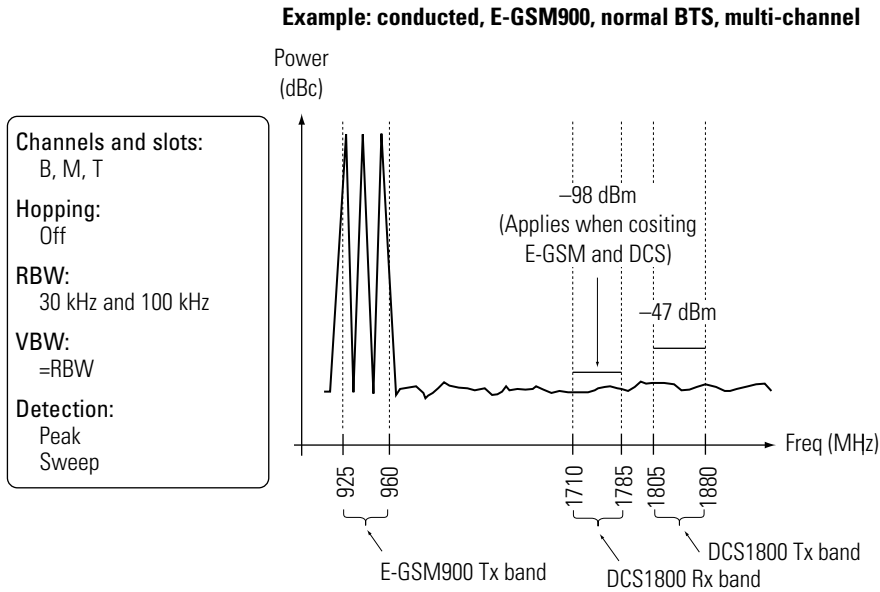

Figure 19. Cross-band spurious, BTS, limits

### Practical measurements

In practice cross-band spurious measurements are grouped with Tx and Rx band spurious measurements and the same techniques are used. The principles described in the explanation of theory in pictures and practical measurements in the spurious section apply.

### When to use the measurement

Applied as Tx and Rx band spurious.

## Out-of-band spurious

The out-of-band spurious is a series of spectrum analyzer measurements over a large frequency range from 100 kHz through to 12.75 GHz (for GSM900). The settings for the measurement are seen in Figure 20.

### Graphical view of limits and specifications

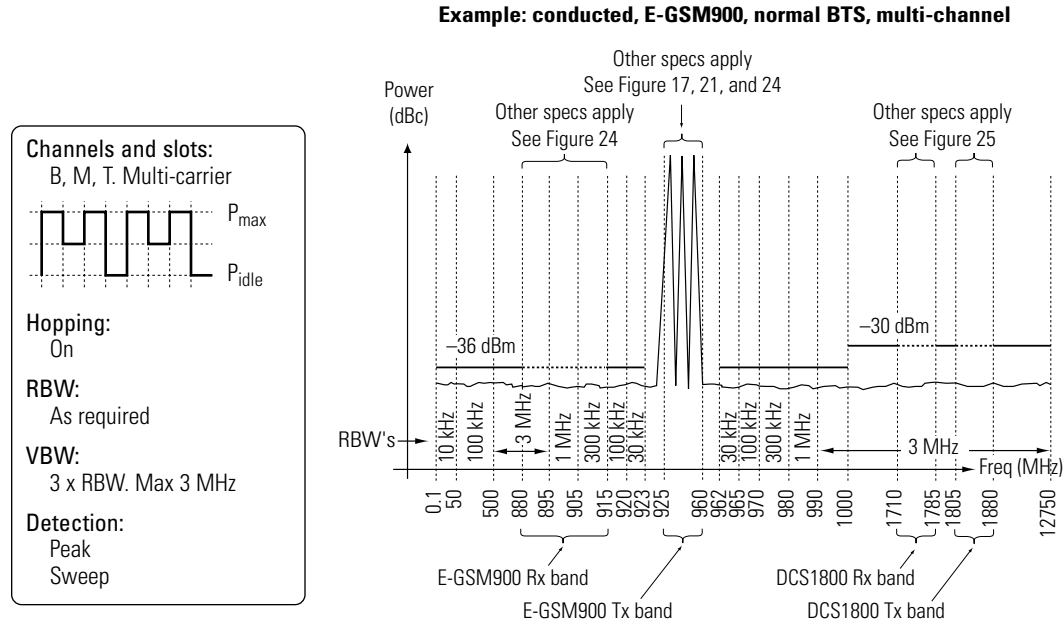

Figure 20. Wideband spurious, BTS, limits

### Practical measurements

In practice, wideband spurious is in fact a series of tests and although thorough, these take some time. Some test equipment automates the process making the measurement straight forward.

### When to use the measurement

Wideband spurious measurements are rarely performed in manufacturing, installation, maintenance or service, however, selected spurious measurements can be made quickly and easily. For example, transmitters are “at risk” at harmonic frequencies. These can be checked easily in manufacturing without a significant time penalty.



## Choosing transmitter measurements for an application

The following table is given for guidance only and the actual measurement set used in any one application is dependent on a number of factors (for example, transmitter design, integration level, or calibration requirements).

<b>BTS Lifecycle Phase</b>	<i>Phase error and mean frequency error</i>	<i>Mean transmitted RF carrier power</i>	<i>Transmitted RF carrier power versus time</i>	<i>Spectrum due to modulation and wideband noise</i>	<i>Spectrum due to switching</i>	<i>Tx and Rx band spurious</i>	<i>Cross-band spurious</i>	<i>Wide band spurious</i>	<i>Other transmitter measurements (not described in this application note)</i>
R&D	Yes	Yes	Yes	Yes	Yes	Yes	Yes	Yes	Yes
Verification	Yes	Yes	Yes	Yes	Yes	Yes	Yes	Yes	Yes
Type approval	Yes	Yes	Yes	Yes	Yes	Yes	Yes	Yes	Yes
Module test	Yes	Yes	Yes	Most	Most	Some	Some	Few	No
Final test	Yes	Yes	Yes	Most	Most	Some	Some	Few	No
QA test	Yes	Yes	Yes	Yes	Yes	Most	Most	Some	Some
Installation	Yes	Yes	Yes	Most	Most	Some	Some	Few	Some
Maintenance	Yes	Yes	Yes	Some	Some	Some	No	No	Some
Depot repair	Yes	Yes	Yes	Most	Most	Some	Some	Few	Some

**Figure 21. BTS measurements by application/lifecycle phase**

# Receiver measurements in GSM basestations

## Introduction

While transmitter power is limited by the GSM standards, there is no limit on the ability of a receiver to acquire a low-level signal under adverse conditions. As a result, receiver characteristics are often the differentiating factor in competing systems. The ETSI GSM 11.21 standard is extensive, but can be summarized with the following tests: sensitivity, signal quality, and selectivity. These tests determine if the basestation can correctly receive signals within its channel and reject interfering signals.

## Metrics

Before performing receiver tests, it is important to understand the metrics used to characterize a receiver's performance. In GSM systems the primary measure of receiver performance is sensitivity. Bit error rate (BER), residual bit error rate (RBER), and frame erasure rate (FER) are the metrics used to evaluate this performance.

### BER

The most common performance metric for digital signal quality is BER. BER is the ratio of the number of erroneous bits received to the total number of bits received. Conceptually, the received bit stream is compared with the transmitted bit stream to detect errors; however, most bit error rate testers use pseudo-random bit sequences to eliminate the need for synchronization between the received and transmitted bits.

Pseudo-random sequences have bit lengths of  $2^n - 1$  where  $n$  is commonly 9 or 15. For example, a PN9 sequence has  $2^9 - 1$  or 511 bits. PN sequences have two properties that make them ideal for BER testing. As the name implies, they appear statistically random when the entire sequence is transmitted. Also, the entire bit stream can be predicted from any given sequence. Because of this second property, it is not necessary to compare the received bit stream with the transmitted bit stream. Instead, the entire bit stream is quickly constructed from the first correct sequence bits. All received bits are then compared with this synthesized sequence. This technique eliminates the difficult synchronization between the transmitted and received bits required in the conventional approach. BER is monitored as the receiver is subjected to low-signal levels, interference and fading.

### RBER

The residual bit error rate (RBER) is performed on demodulated speech frames that are not marked corrupt. A frame is labeled corrupt if the test on the parity bits or cyclic redundancy check (CRC) is not successful. There are two types of RBER: RBER Ib and RBER II. Each one evaluates different portions of the demodulated, decoded speech frame. To better explain the different portions of the speech frame, this note first examines how speech is coded in GSM.

## GSM speech coding

To transmit actual voice data would require more bandwidth than a system can practically afford. Most digital communication systems use some sort of voice compression. GSM is no exception. The encoding goal is to represent speech with the least amount of bits.

Human speech consists of an excitation signal (pitch, loudness) a filter (tongue, teeth), and redundancy (long vowels and pauses). The GSM speech encoder produces 260 bits every 20 ms that represent the human voice. The output bits are separated into groups by their importance at reproducing an acceptable representation of speech. The most important bits are the Class Ia bits. These bits contain filter coefficients, and receive the most protection during the channel coding process. Next in importance are the Class Ib bits, and least important are the Class II bits. Class II bits do not receive additional protection from the channel coder.

During channel decoding, the CRC must be successful or the entire frame is discarded. Once CRC is verified Class Ib and Class II bits are checked for errors. The RBER test then becomes bit errors in accepted frames over the total number of bits in the accepted frames.

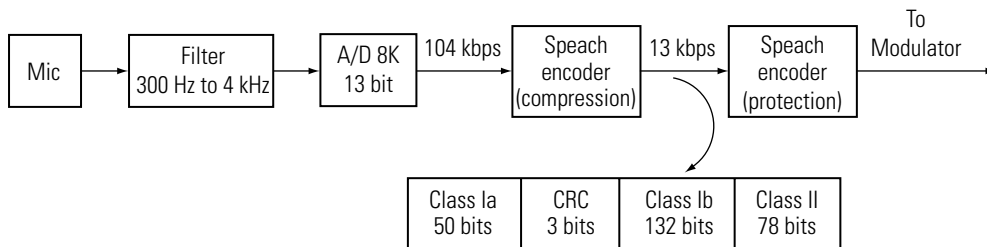

## FER

The frame erasure rate (FER) indicates how many of the received frames are bad. The channel decoder erases frames when the CRC fails. FER is performed on both speech and signaling frames. When a speech frame is discarded, the system will interpolate. When a signaling frame is discarded, the mobile station is instructed to resend. In the GSM standards, it is common to see FER limits multiplied by correctional value  $\alpha$ . This correction factor allows the system designer to trade off between FER and RBER. If the system is designed to discard a large number of frames, then the FER will be higher (multiply by  $\alpha$ ) and RBER should be significantly lower (divide by  $\alpha$ ). Values for  $\alpha$  range between 1 and 1.6.

## Measurements

### Test setups

#### Abis versus loopback

In normal operation, the GSM basestation receives signals from the mobile over the air interface, demodulates and decodes the signal, then sends the data to the basestation controller (BSC) over the network interface (Abis). Controlling the basestation using Abis is a critical part of R&D test and type approval. Abis testing emulates actual operation of the basestation, and verifies functions such as signal strength (RX-LEV), signal quality (RX-QUAL), and frame erasure indication (FEI).

It is common in manufacturing to test the basestation or its transceiver units (TRX's) using the loopback method. During loopback the received signal is demodulated, decoded, then encoded, modulated and re-transmitted. Recently many manufacturers have begun using the loopback method in final test because the Abis interface can be device independent.

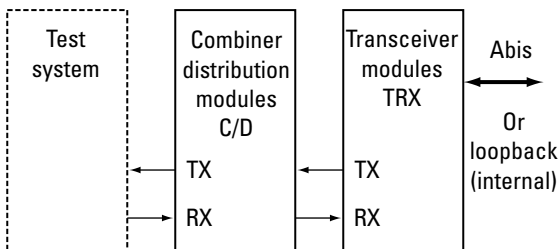

#### Static versus multipath propagation

Static testing refers to the ideal propagation condition. The test signal is connected directly to the TX or RX port. Static testing is the method most used in manufacturing and service. Multipath propagation testing refers to the simulation of various conditions that create interference in the propagation environment. The GSM specification describes three different propagation conditions: Typical urban terrain (TU), rural area terrain (RA), and hilly terrain (HT). Each terrain will include a speed parameter. For example, TU50 specifies an urban fading profile, which is passed through at a speed of 50 km/hr. RF channel fading simulators are used in R&D and during full type approval.

## Static reference sensitivity level

### Purpose of measurements—what it proves

Sensitivity is the most significant in-channel receiver test. The sensitivity test proves that the receiver can receive, demodulate, and decode a very low-level signal. Every base station manufacturer does this test. This test also proves adjacent time slot rejection. The two adjacent time slots are required to have a 50 dB level above the time slot under test.

### Theory in pictures

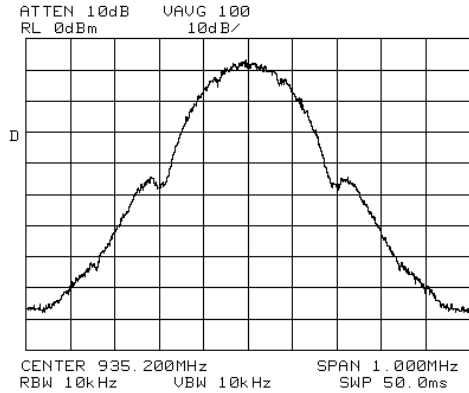

Input signal in frequency domain

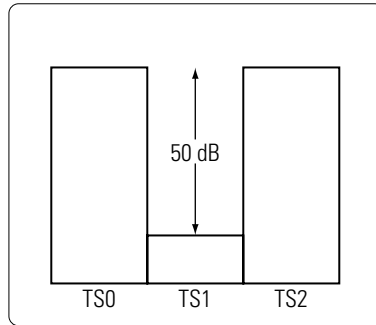

Input signal in time domain

### Graphical view of limits and specifications

Channel Type	Error Parameter	Limit Value %
RACH	FER	0.5
TCH/F9.6	BER	0.001
TCH/FS	FER	$0.1\alpha$
Class Ib	RBER	$0.4/\alpha$
Class II	RBER	2

**Practical measurements**

In practice, there are really two values of sensitivity, compliance sensitivity and absolute sensitivity. To verify compliance sensitivity, a GSM modulated signal with a power level of -104 dBm is applied to the receiver and RBER class II is verified to be below 2%.

To verify absolute sensitivity, a GSM modulated signal is applied at a nominal level (-90 dBm) and decreased until the specified BER occurs. This sensitivity level contributes enormously to overall system performance. Sensitivity is the network equipment manufacturer's most important specification. A few dB of added sensitivity performance can reduce the mobile stations required transmit power, or reduce the number of dropped calls in a hostile environment.

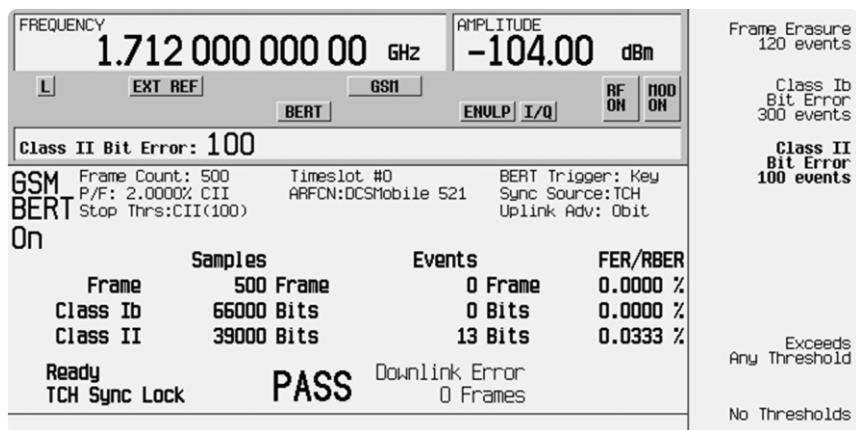
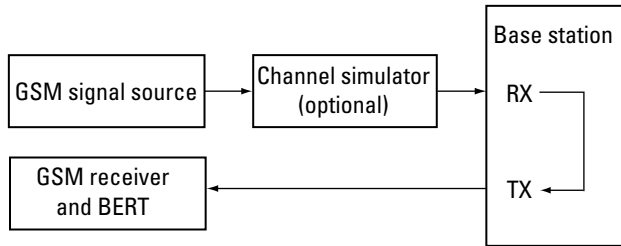

Figure 26. BER results shown on Agilent ESG E4433B, digital RF signal generator

**When to use the measurement**

Sensitivity measurements are performed in every phase of the BTS lifecycle. In final manufacturing tests, BER, RBER, and FER are typically verified at bottom, middle, and top frequencies using a traffic channel. During full type approval, a thorough list of different channel configurations and specification limits are used to verify performance.

## Reference interference level

### Purpose of measurements—what it proves

Reference interference level tests the receiver's ability to demodulate and decode a GSM signal in the presence of an interfering signal. This ETSI specification covers both co-channel and adjacent channel interference. For co-channel testing, two GSM modulated signals are applied to the receiver. The wanted signal level is 9 dB above the interfering signal level.

For adjacent channel testing, two GSM modulated signals are applied to the receiver. This time the interfering signal will be 200 kHz offset and 9 dB above the wanted signal. The adjacent channel test is repeated at 400 kHz offset and 41 dB above the wanted signal.

### Theory in pictures

Co-channel rejection  
 Wanted signal  $-84$  dBm  
 Interfering signal  $-95$  dBm

Adjacent channel rejection  
 Wanted signal  $-84$  dBm  
 Interfering signal  $-75$  dBm + 200 kHz

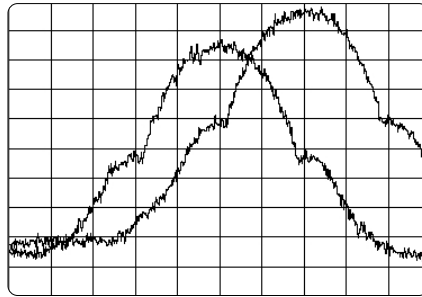
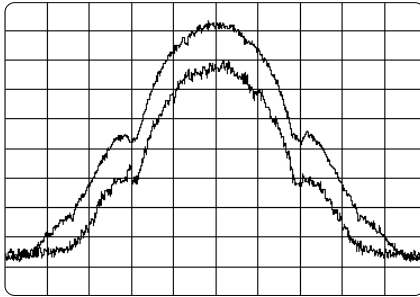

### Graphical view of limits and specifications

Channel Type	Error Parameter	Limit Value %
RACH	FER	16
TCH/F9.6	BER	0.8
TCH/FS	FER	$6\alpha$
Class Ib	RBER	$0.4/\alpha$
Class II	RBER	8

### Practical measurements

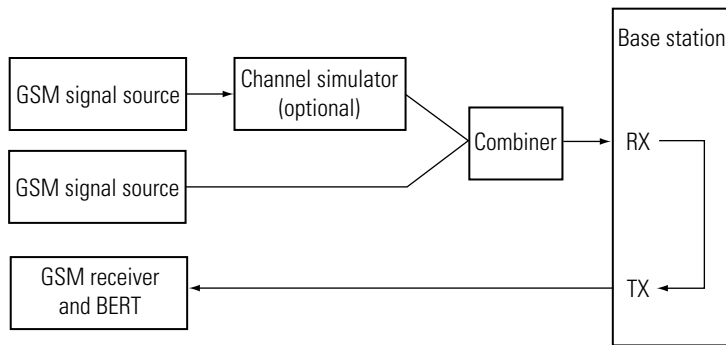

### When to use the measurement

Interference measurements are also performed in every phase of the BTS lifecycle. During full type approval a comprehensive list of different channel configurations are used to verify performance.



## **Additional ETSI 11.21 receiver tests**

In addition to the Sensitivity and Reference Interference Level tests, the ETSI 11.21 standard includes two functional tests and three additional selectivity tests briefly described below:

### **Static layer RX function**

This functional test verifies the operation of the demodulation and decoding process. A GSM modulated traffic channel is applied and the unprotected class II bits are evaluated.

### **Erroneous frame indication performance**

This functional test verifies the operation of the bad frame indication (BFI) and the frame erasure indication (FEI). The base station RX input is terminated, and all frames should be marked as bad and erased.

### **Blocking characteristics**

This selectivity test verifies that the receiver can perform in the presence of a strong CW signal. The CW signal shall be any frequency >600 kHz away from the wanted GSM signal.

### **Intermodulation characteristics**

This selectivity test verifies that the receiver can perform in the presence of a strong GSM and CW signal whose frequencies are selected to produce in-channel intermodulation products.

### **AM suppression**

This selectivity test verifies that the receiver can perform in the presence of a strong GSM signal >6 MHz away.

## Summary

This application note explains and describes the key transmitter and receiver measurements required for testing GSM. The ETSI and ANSI test specifications have been created for type approval purposes and are therefore extensive, however, at any stage of the BTS lifecycle it is sensible to use these standards as a starting point. It is essential to optimize the test suite for any one application and balance test coverage, cost, speed and test system flexibility. This application note should assist that process, as well as providing a useful reference. Modern test equipment is often designed for one or a few select applications.

## References

1. GSM 05.05/ETS 300-577. GSM and DCS1800 Radio transmission and reception.
2. GSM 11.10/ETS 300-607. GSM and DCS1800 Mobile Station (MS) conformance specification. Part 1: Conformance specification.
3. GSM 11.21/ETS 300-609. Base Station System (BSS) equipment specification. Part 1: Radio aspects.
4. ANSI J-STD-007. PCS1900. Air Interface Specifications.
5. *GSM Measurement Basics*. 1994. Hewlett-Packard Symposium.
6. *Selecting GSM Measurements for Your Application*. 1994. Hewlett-Packard Symposium.
7. *Understanding CDMA Measurements for Base Stations and their Components, Application Note 1311*, literature number 5968-0953E
8. *VSA Transmitter Tester, User's Manual*, part number E4406-90007.
9. *85727A GSM Multiband Transmitter Measurements Personality (for 859X Spectrum Analyzer), User's Manual*, part number 85727-90001. Rev A.01.01
10. *8922 User's Manual*, part number 08922-90211

For more information about Agilent Technologies test and measurement products, applications, services, and for a current sales office listing, visit our web site:

<http://www.agilent.com/find/tmdir>

You can also contact one of the following centers and ask for a test and measurement sales representative.

**United States:**

Agilent Technologies  
Test and Measurement Call Center  
P.O. Box 4026  
Englewood, CO 80155-4026  
(tel) 1 800 452 4844

**Canada:**

Agilent Technologies Canada Inc.  
5150 Spectrum Way  
Mississauga, Ontario, L4W 5G1  
(tel) 1 877 894 4414

**Europe:**

Agilent Technologies  
European Marketing Organization  
P.O. Box 999  
1180 AZ Amstelveen  
The Netherlands  
(tel) (31 20) 547 9999

**Japan:**

Agilent Technologies Japan Ltd.  
Measurement Assistance Center  
9-1, Takakura-Cho, Hachioji-Shi,  
Tokyo 192-8510, Japan  
(tel) (81) 426 56 7832  
(fax) (81) 426 56 7840

**Latin America:**

Agilent Technologies  
Latin American Region Headquarters  
5200 Blue Lagoon Drive, Suite #950  
Miami, Florida 33126, U.S.A.  
(tel) (305) 267 4245  
(fax) (305) 267 4286

**Australia/New Zealand:**

Agilent Technologies Australia Pty Ltd  
347 Burwood Highway  
Forest Hill, Victoria 3131  
(tel) 1-800 629 485 (Australia)  
(fax) (61 3) 9272 0749  
(tel) 0 800 738 378 (New Zealand)  
(fax) (64 4) 802 6881

**Asia Pacific:**

Agilent Technologies  
24/F, Cityplaza One, 1111 King's Road,  
Taikoo Shing, Hong Kong  
(tel) (852) 3197 7777  
(fax) (852) 2506 9284

Technical data is subject to change  
Copyright © 2000  
Agilent Technologies  
Printed in U.S.A. 2/00  
5968-2320E

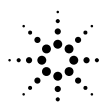

**Agilent Technologies**  
Innovating the HP Way